



MPO™ Series

Oil-Fired, High Efficiency, 3-Pass
Water Boilers

87%

HIGH EFFICIENCY



- High Efficiency 87% AFUE
- 3-pass Cast Iron Sectional Design
- Built-in Return Water Temperature Protection
- Natural Draft Oil Boiler
 - Five Sizes Available, 0.60-1.65 gallons
- Direct Vent Option Kit
 - Three Sizes Available, 1.05-1.65 gallons
- Easy Installation and Servicing with Reversible Swing Door and no Target Wall or Blanket Required
- Multiple Burner Options



Burnham
Hydronics

MPO™ Series

Oil-Fired, High Efficiency,
3-Pass Water Boilers

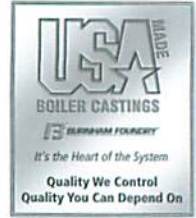
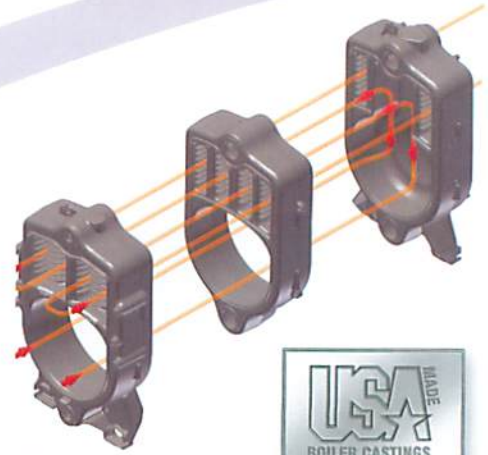

Burnham's MPO Boiler

Unique 3-Pass Cast Iron Design

The MPO boiler has been exclusively designed by Burnham engineers to use a 3-pass cast iron sectional design that is unequalled in the industry. MPO sections are produced in Burnham's own state-of-the-art foundry in Zanesville, Ohio, and are the primary reason why the MPO is able to attain an ENERGY STAR-certified 87% AFUE.

Built-in Return Water Boiler Protection

Every MPO boiler comes equipped with a unique return water blending device that automatically mixes hot boiler water with cool return water. This device also aids in keeping temperatures consistent within the boiler which provides greater operational efficiencies and allow the boiler to operate with virtually any type of hot water system.



Easy to Install, Maintain, and Service

From installation to service, the MPO has been designed with the contractor in mind. Installation features include a plug-and-play wiring junction box with easy plug-in control and accessory connections, and a reversible swing-away door with an easy connect power cord for the burner. The MPO includes a Honeywell electronic high-limit aquastat and provisions for optional plug-in accessories, such as a low water cutoff or an additional high-limit. For maintenance and servicing, the MPO comes equipped with reversible stainless steel flueway baffles, rear cleanout access plates, and ample flueway clearance for easy cleaning.



Multiple Burner Options

Burnham offers the flexibility of multiple burner choices for the MPO boiler. A selection of burners from industry-leading manufacturers is available for all MPO sizes*.

MPO Direct Vent Kit

No chimney? The MPO-DV (Direct Vent) Option Kit is the perfect solution! The venting kit includes a stainless steel sidewall concentric vent/air intake termination. To connect the boiler flue connects to this piece, a flexible stainless steel, double wall, insulated pipe is also available in 5, 10, 15, and 20 foot lengths. Intake air for combustion connects directly from the burner housing to the vent terminal with a 4" galvanized single wall pipe.



Additional Venting Options

MPO-DV Option Kit's flexible stainless steel pipe permits installation in just about every application where a chimney is not available. For added convenience in installations where there is little clearance behind the boiler, optional stainless steel "starter tees" are now available. These tees fit directly to the rear of the boiler and allow for the pipe to be connected vertically. This dramatically reduces the footprint of the boiler installation, by allowing the MPO to be installed close to a wall. Featuring welded stainless steel construction, the tees are equipped with a convenient, handle-operated, removable bottom cleanout plate.



B5 approved for Beckett burners

* Direct Vent boilers require the use of dedicated direct-vent compatible burners, such as the Beckett NX. Additional burners may be available, please contact your Burnham supplier for details.



Honeywell Aquastat

The standard Honeywell L7248 electronic aquastat, includes digital display and interface capability to provide diagnostic information.

3" Insulation

Surrounds boiler block which reduces heat loss through the boiler jacket.



Removable Flueway Baffles

Allow the MPO to be installed in a variety of chimney applications and permit easy cleaning

Reversible Swing-Away Burner Door

Offers easy access to combustion chamber for cleaning.

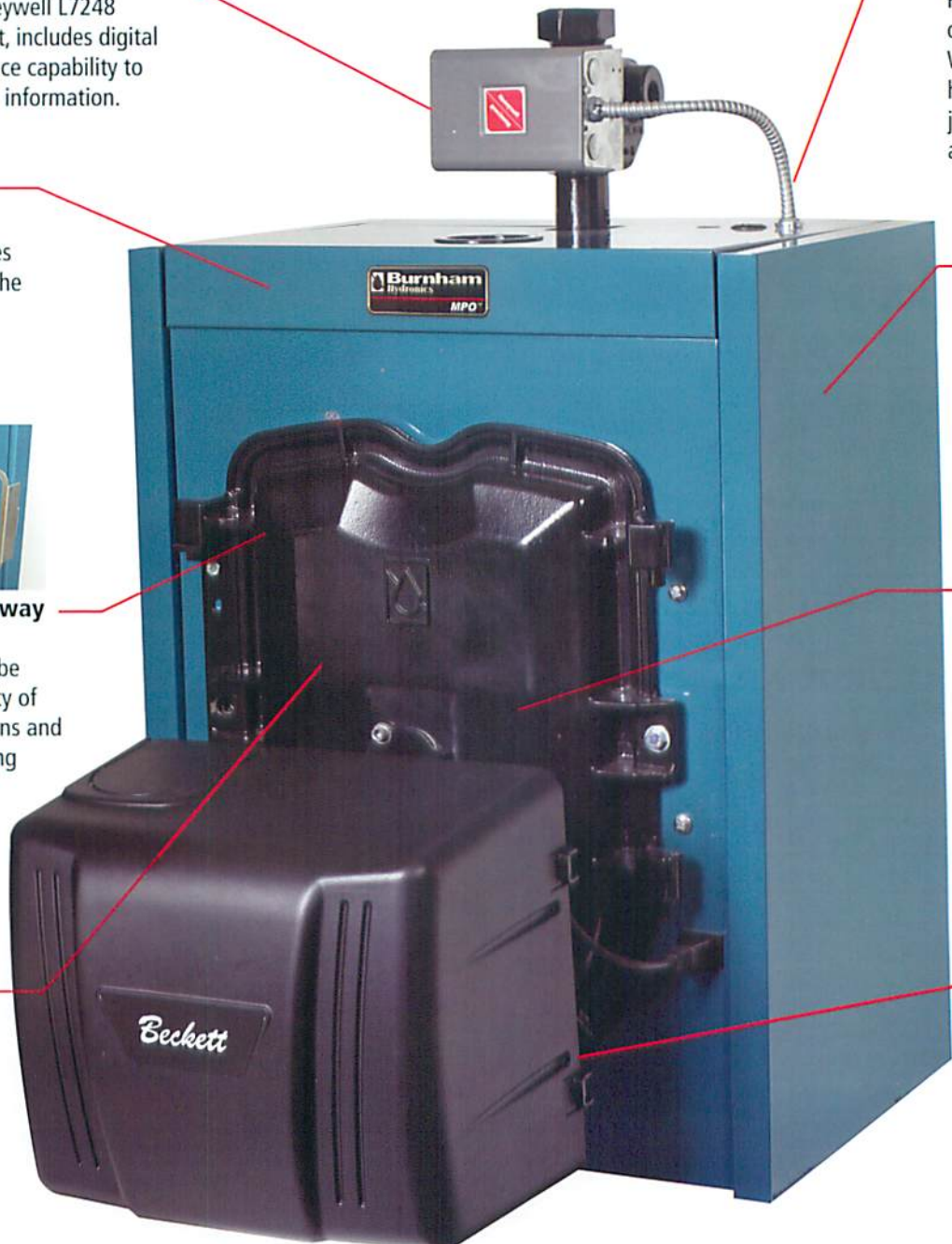

Plug-In Connectors, Concealed Wiring Harness

Provides easy hook-up of additional controls, Wiring harness is hidden beneath the jacket, providing a clean appearance.

3-Pass Cast Iron Heat Exchanger

Flue gases are recirculated through the heat exchanger, extracting the maximum BTUs possible from the combustion process.

Large, Geometric Combustion Chamber

Without a target wall or blanket, increases heat transfer and reduces costs on repair parts.

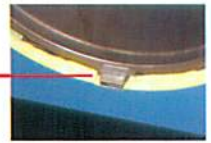

Integrated Boiler Door Support

Holds weight of boiler swing door in closed position, reducing stress & wear on hinges.

Burnham Alliance SL™

Indirect-fired Water Heaters

The Alliance SL water heaters are designed with an effective hydrastone lining that offers superior corrosion resistance and outstanding performance in a wide variety of water conditions.

Water heaters are available in five sizes from 27-119 gallons, and come with a unique 10/2/1 warranty – 10 years on the tank and coil, 2 years labor and 1 year on parts.



Ratings



Model Number	Burner Capacity (GPH)	DOE Heating Capacity (MBH)	I=B=R Water Ratings	ENERGY STAR AFUE%
MPO84	.60	74	64	87
MPO115	.80	98	85	87
MPO147	1.05	129	112	87
MPO189	1.35	167	145	87
MPO231	1.65	203	177	87

Specifications

Model Number	Dimensions (inches)			Water Content (gal.)	Natural Vent Approximate Shipping Weight (lbs.)	Direct Vent Approximate Shipping Weight (lbs.)
	'A'	'B'	'C'			
MPO84	16-5/8	24	5	7.70	475	N/A
MPO115	16-5/8	24	5	7.70	475	N/A
MPO147	22-5/8	24	6	11.08	567	579
MPO189	28-5/8	30	6	14.46	659	692
MPO231	34-5/8	30	7	17.84	751	807

MPO Direct Vent Kit

Model Number	Vent Connector Diameter (inches)	Optional Starter "T" Depth 'D' (Inches)
MPO147	5	14
MPO189	5	14.5
MPO231	6	14.5

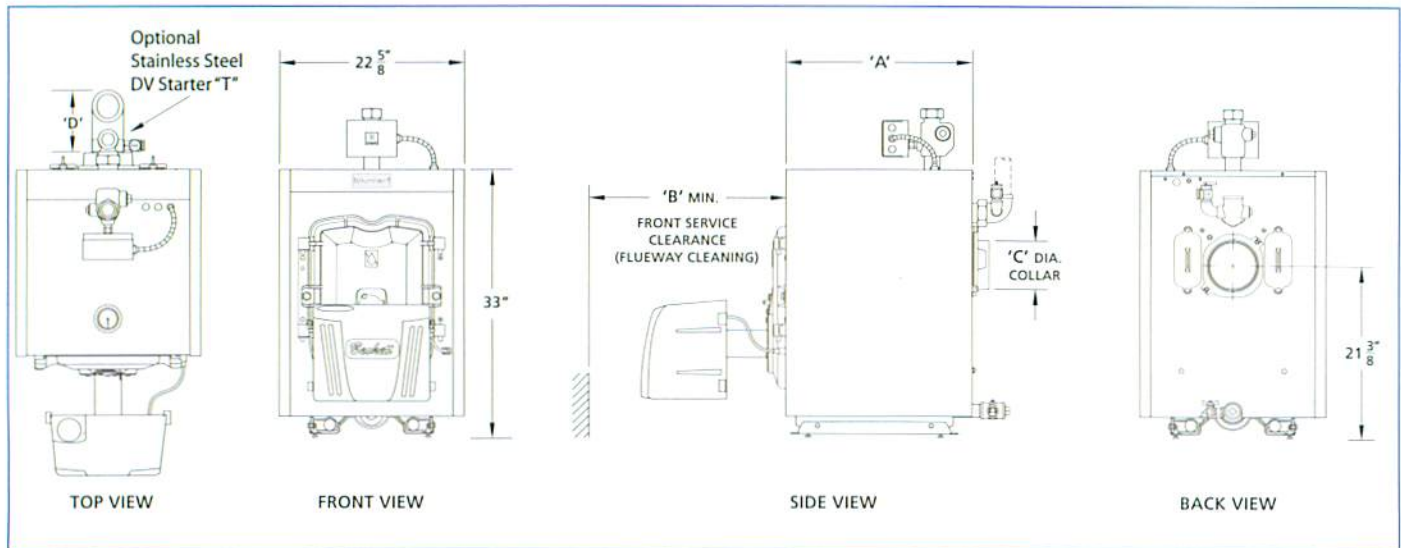

www.burnham.com

© 2008 U.S. Boiler Company, Inc. - Lancaster, PA
 Phone: 1-888-432-8887
www.burnham.com